

SONO-DYNE INC.

U.S. Corp. Office

Canadian Office,

1151 Creek
Woods Circle,
St. Cloud Fla. 34772
Tel. 407 761 5976
Fax. 705 727 0535

1-300A Shanty Bay Rd.
Barrie, Ont. L4M 1E6
Canada
Tel. 705 727 1488
Fax. 705 727 0535

FOAM TENSILE STRENGTH TESTER

Specifications:

- Length of excursion; 6.0"
- Maximum force; 50 lbs, to 100 lbs. available.
- Force measurement accuracy; ± 0.5 lbs.
- Displacement measurement accuracy; ± 0.001 in.

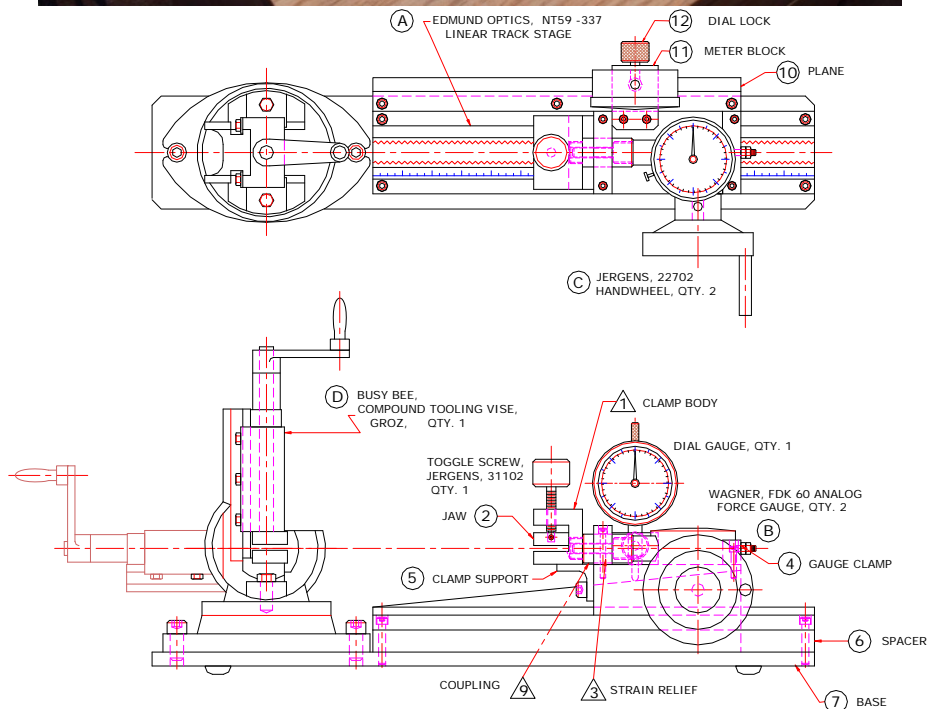

Price; \$ 1900 U.S.